

## CORAZZATO

### SHEATHED ELEMENT

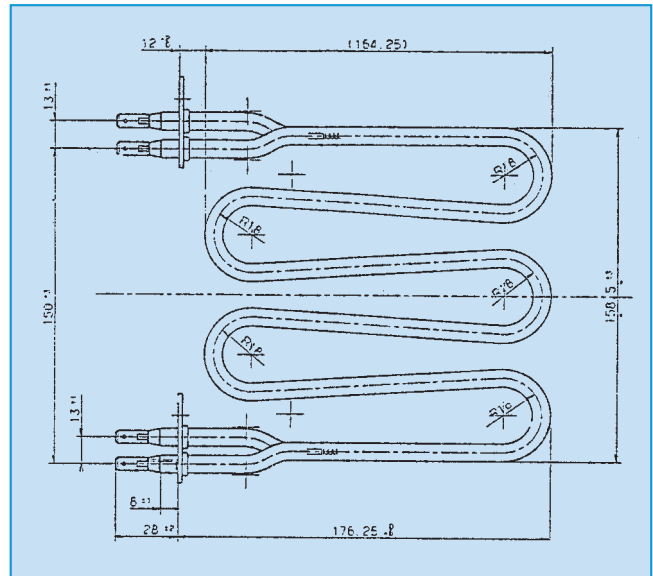
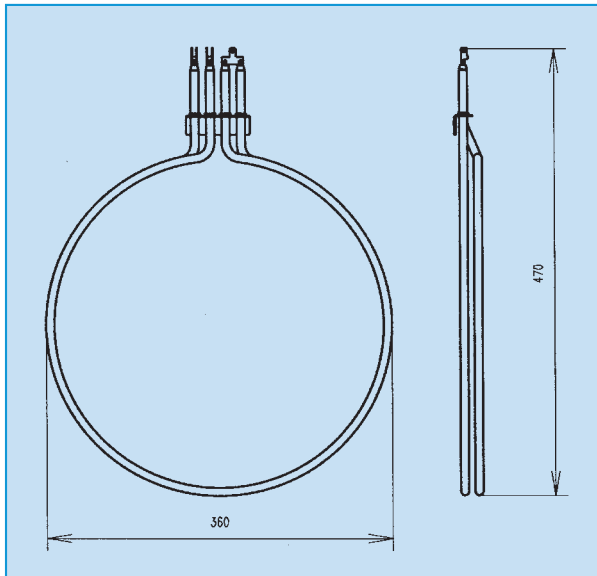

Viene realizzato utilizzando corazze particolarmente resistenti alla ossidazione e subiscono un trattamento superficiale che ne esalta l'emissività termica.

*This type of heating element features a cover that is particularly resistant to oxidation. It undergoes a surface thermic treatment to increase its thermal emissivity*

## FILO NUDO

### OPEN COIL ELEMENT

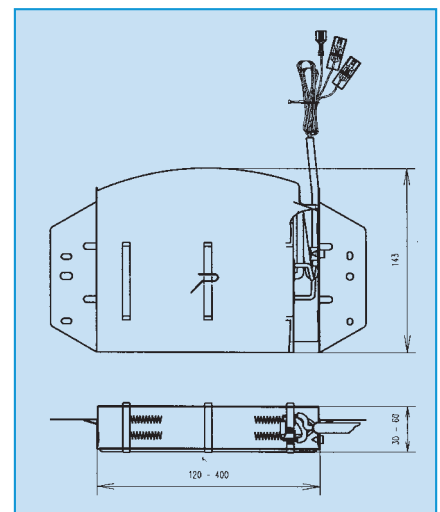
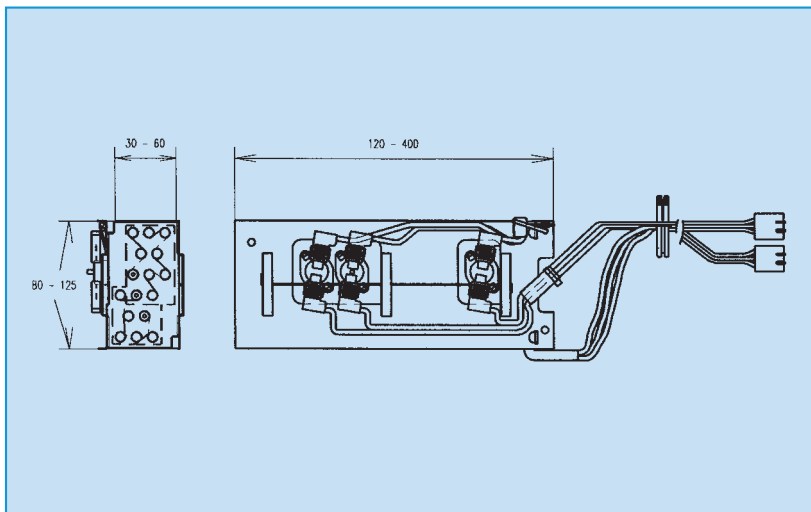

# ALLUMINIO

## ALUMINIUM

| FAMIGLIA<br>FAMILY | TIPO ELEMENTO<br>TYPE OF ELEMENT    | PROTEZIONI<br>SAFETY DEVICES                   | TENSIONE<br>VOLTAGE<br>RANGE | POTENZA<br>POWER RANGE |
|--------------------|-------------------------------------|--|------------------------------|------------------------|
| DRYER              | CORAZZATO Ø 8.5<br>SHEATHED Ø 8.5   | NESSUNA PROTEZIONE<br>NO SAFETY DEVICE         | 60V - 400V                   | 200W - 3200W           |
|                    | CORAZZATO Ø 6.25<br>SHEATHED Ø 6.25 | NO SAFETY DEVICE                               |                              | 120W - 3200W           |
|                    | FILO NUDO<br>OPEN COIL<br>ELEMENT   | NESSUNA PROTEZIONE<br>NO SAFETY DEVICE         | 200V - 400V                  | 1500W - 6000W          |
|                    |                                     | TERMOST. MAN. O AUT.<br>MAN. OR AUT. THERMOST. |                              | 1500W - 4000W          |
|                    |                                     | TERMOFUSIBILE<br>THERMAL FUSE                  |                              | 1500W - 3000W          |
|                    | ALLUMINIO<br>ALUMINIUM              | NESSUNA PROTEZIONE<br>NO SAFETY DEVICE         | 60V - 400V                   | 1000W - 2500W          |
|                    |                                     | TERMOST. MAN. O AUT.<br>MAN. OR AUT. THERMOST. |                              |                        |
|                    |                                     | TERMOFUSIBILE<br>THERMAL FUSE                  |                              |                        |

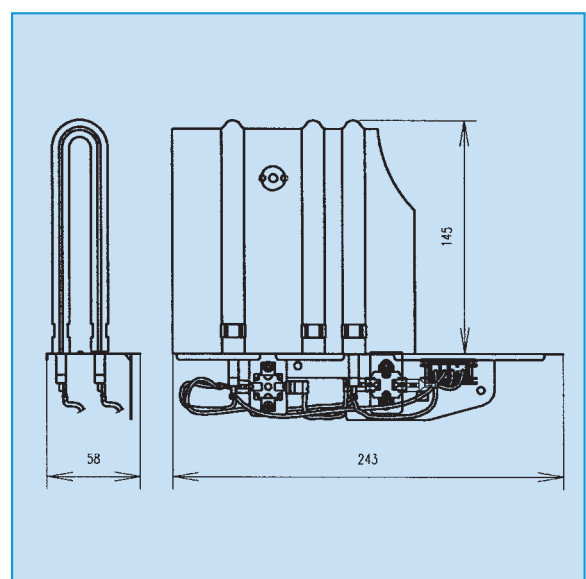
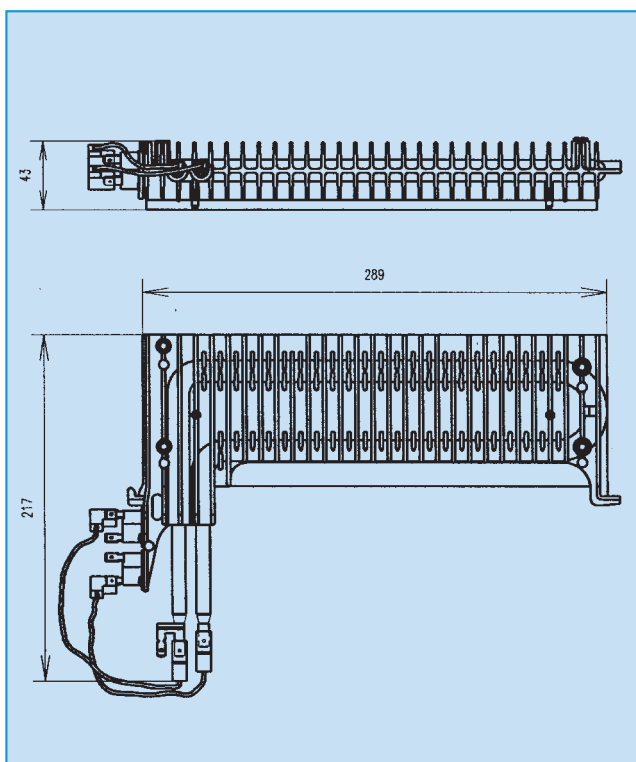

ESTRUSI  
EXTRUDED UNITS

PRESSOFUSI  
DIE-CASTING UNITS

